

HORSEBOX BROCHURE

ALL INFORMATION ON THE PRODUCTS
AVAILABLE

*180 Front
Window View*



*Different size models
to fit your horse*

Front Ramp

THE STORY

Ifor Williams offers a superbly engineered range of horsebox trailers with an all-aluminium body and streamlined designs.

The soft curves and unique floating roof design merge together to offer stunning lines, complemented further by the large stylish front window. All of these elements together give the **HBX** range a highly recognisable, unique and iconic design.

Trailer exteriors of the **HB** range have a striking overall appearance which complements popular models of 4x4 vehicles on the road today. However, the beauty of our horsebox is not just skin deep, the comfort and safety of your horse has always been our main consideration in the design of our horsebox range.

Since 1958, people have put their trust in our trailers, just ask an owner - they're not difficult to find. With 60 years of engineering experience we proudly present this truly exceptional horsebox. As befits the latest addition to the prestigious **HB** range, the **HBX** builds on the decades of expertise and knowledge of Ifor Williams Trailers while simultaneously introducing a striking new design that sets it apart.

The result reflects our investment in new technologies, processes and materials that ensure our products continue to exceed our customers' expectations. For the discerning horse owner, no other horsebox trailer comes close.







DESIGNED FOR YOUR HORSE

In the development of the beautifully engineered HBX range, as well as creating a stunning trailer to look at, the ultimate objective was to produce a horsebox that delivers the highest levels of comfort and safety for your horse. Every detail has been meticulously considered to ensure every journey is smooth, comfortable and effortless.

Our dedicated design team has created a stunning range of horseboxes with a sophisticated new aesthetic that reflects the look of today's most desirable SUV's. Soft curves flow into each other in an elegant display of aerodynamic styling.

Carefully selected materials and superb attention to even the smallest detail means our HBX is safe and strong whilst being extremely attractive on the road. It's all part of our assurance of quality, strength, value and easy maintenance that make Ifor Williams Trailers the obvious choice.

The HBX range features three models - one suitable for single horse transport and two different sized double horseboxes.



HBX506

THE HBX-506 DOUBLE HORSEBOX IS IDEAL FOR TRANSPORTING TWO HORSES UP TO 16.2HH. IT IS AVAILABLE WITH THE OPTION OF EITHER A FRONT RAMP OR A BUILT-IN TACK LOCKER. IT FEATURES A PAIR OF SIDE WINDOWS, A LARGE INSPECTION WINDOW, CENTRE PARTITIONS WITH BREAST AND BREECHING BARS AS STANDARD.

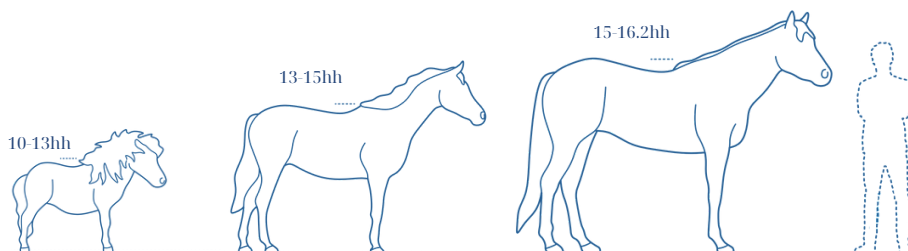

HEIGHT SCALE FOR HORSES SUITABLE FOR HBX506

DOES YOUR HORSE FIT?

HBX511

THE SLIGHTLY LONGER AND WIDER **HBX-511** DOUBLE HORSEBOX WILL COMFORTABLY ACCOMMODATE TWO 17.2HH HORSES. LIKE THE HBX-506 THIS HORSEBOX IS AVAILABLE WITH THE OPTION OF EITHER A FRONT RAMP OR A BUILT-IN TACK LOCKER. THE HBX-511 ALSO FEATURES A PAIR OF SIDE WINDOWS, A LARGE INSPECTION WINDOW, CENTRE PARTITIONS WITH BREAST AND BREECHING BARS AS STANDARD.

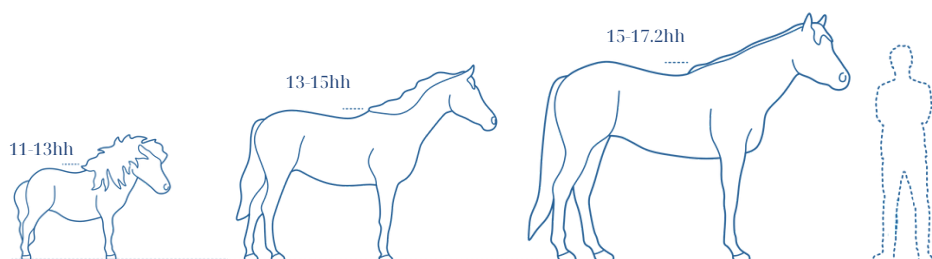

HEIGHT SCALE FOR HORSES SUITABLE FOR HBX511

DOES YOUR HORSE FIT?

TACK LOCKER OPTION



Providing useful space for all your equipment, the tack locker can be selected as an alternative to the front ramp. It is built into the front nose area of your horsebox and is accessible from the outside through a side locker door. The tack locker is only available on the left hand side.

Tack locker includes:

- Adjustable height dual saddle rack (18")
- Whip rack
- Two shelves
- Bridle hooks
- Space for saddles 80cm x 60cm
- Tack locker interior lamp



SPECIFICATIONS

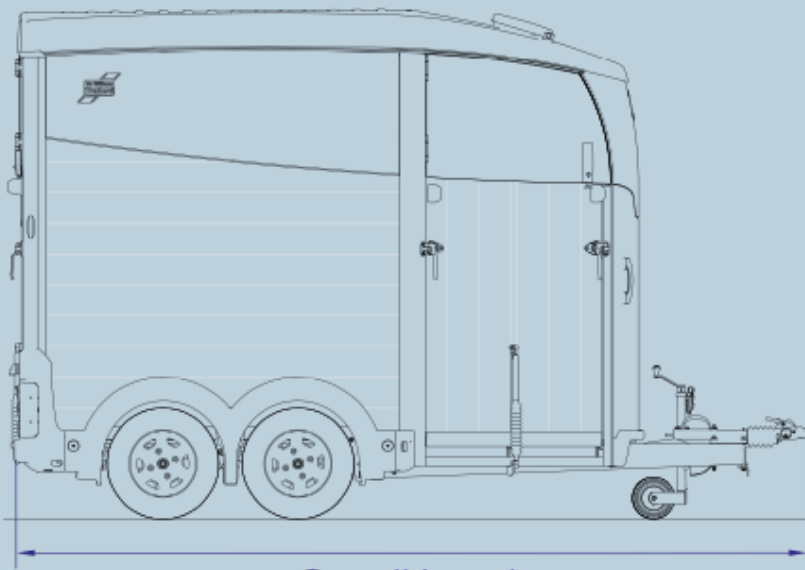

Overall Length



Choose from three colour options, all with colour co-ordinated front panel and roof. Colours have been carefully selected to complement the colours of popular towing vehicles.

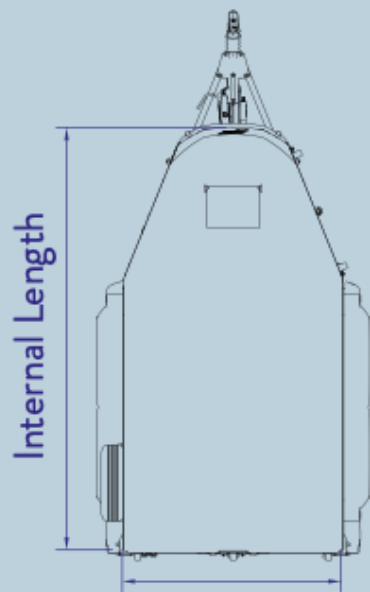

Internal Length

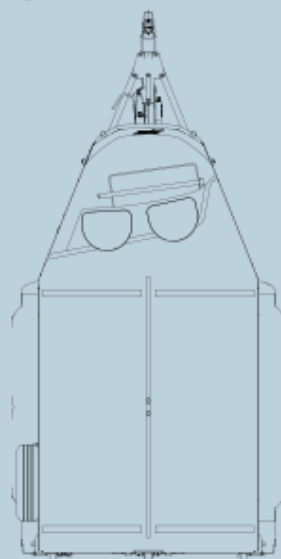

Shown with Tack Locker

Internal Width

	HBX 506	HBX 511
Tyres	165R13C	165R13C
Maximum gross weight	2600kg	2700kg
Unladen weight	865kg	950kg
Overall height	2.74m	2.75m
Overall width	2.14m	2.27m
Overall length	4.30m	4.67m
Internal height	2.29m	2.29m
Internal width	1.67m	1.79m
Internal length	3.26m	3.63m
Stall width	0.83m	0.89m
Stall length min/max	1.43/1.83m	1.65/2.04m
Breast/breeching bar height	0.95/1.27m	0.95/1.27m

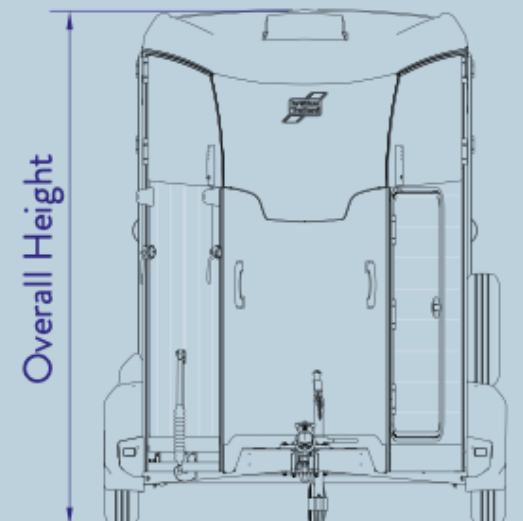

Overall Height

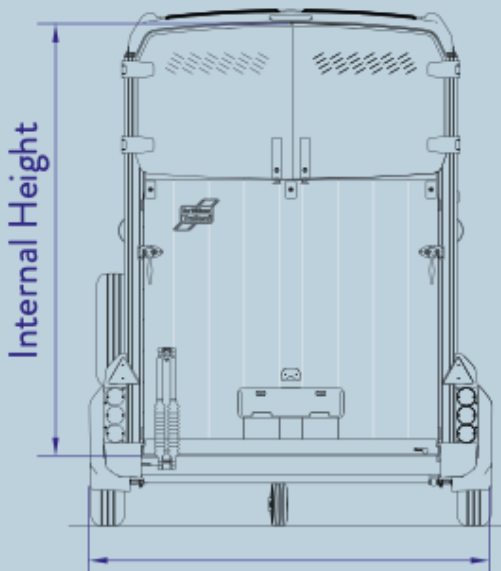

Internal Height

Overall Width

THE WORLD'S BEST TRAILERS



HB506

THE **HB-506** DOUBLE HORSEBOX IS IDEAL FOR TRANSPORTING TWO HORSES UP TO 16.2HH. IT IS AVAILABLE WITH A STANDARD FRONT RAMP. THE MODEL FEATURES A PAIR OF SLIDING SIDE WINDOWS, AND HAVE A LARGE INSPECTION WINDOW WHICH ALLOWS MORE DAYLIGHT INTO THE TRAILER. CENTRE PARTITIONS AND BREAST AND BREECHING BARS ARE FITTED AS STANDARD.

Rear top doors and high level break lights

Front panel and window

Tack Pack™ - Wheeled
Fits neatly into the nose area of the trailer, and can be wheeled down the front ramp to empty and load. Available in silver. Suitable for general purpose saddles up to 18" (46cm). We advise that you check saddles fit before tack pack is purchased.

Interior sliding hay net rail and ring. Along with a standard stallion partition

Auto lift jockey wheel

Breast bar release system
Compatible with the wheel brace supplied, enables the release of breast bars safely from outside of the horsebox.

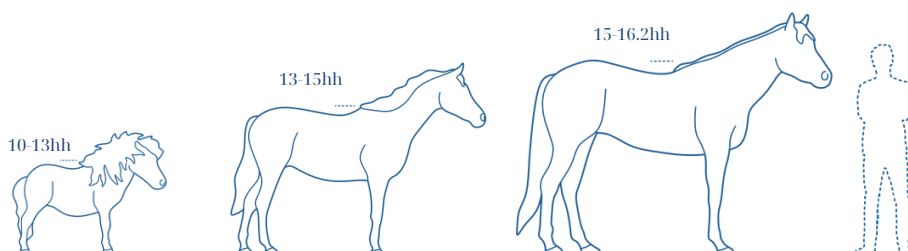

HEIGHT SCALE FOR HORSES SUITABLE FOR HB506

DOES YOUR HORSE FIT?

HB511

THE SLIGHTLY LONGER AND WIDER **HB-511** DOUBLE HORSEBOX WILL COMFORTABLY ACCOMMODATE TWO 17.2HH HORSES. IT IS AVAILABLE WITH A STANDARD FRONT RAMP. LIKE THE HB-506 ALSO FEATURES A PAIR OF SLIDING SIDE WINDOWS, AND HAVE A LARGE INSPECTION WINDOW WHICH ALLOWS MORE DAYLIGHT INTO THE TRAILER. CENTRE PARTITIONS AND BREAST AND BREECHING BARS ARE FITTED AS STANDARD.

Rear top doors and high level break lights

Front panel and window

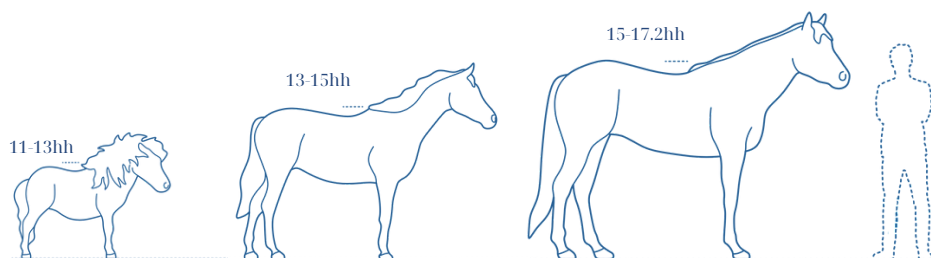

HEIGHT SCALE FOR HORSES SUITABLE FOR HB511

DOES YOUR HORSE FIT?

SPECIFICATIONS

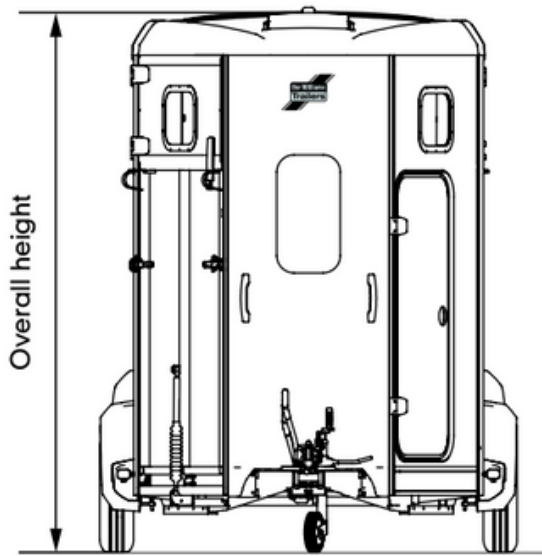

Choose from six colour (Bala blue, graphite, green, red, silver or black) options, all with colour co-ordinated panels and silver roofs. Colours have been carefully selected to complement the colours of popular towing vehicles.

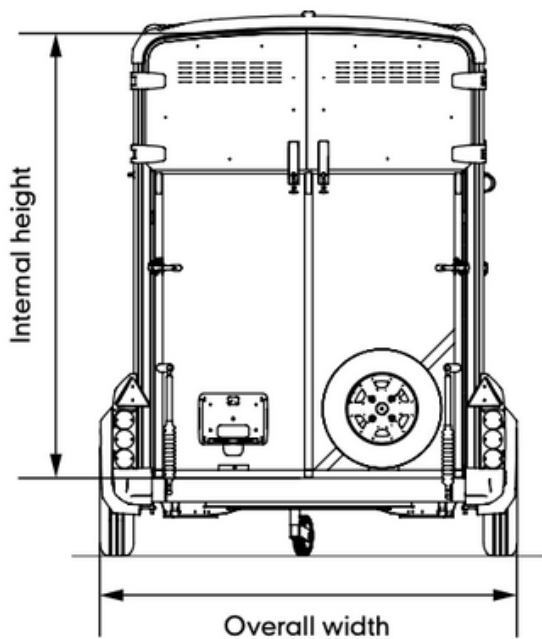

	HB506	HB511
Tyres	165R13C	165R13C
Maximum gross weight	2600kg	2700kg
Unladen weight	920kg	1000kg
Overall height	2.75m	2.75m
Overall width	2.13m	2.26m
Overall length	4.30m	4.65m
Internal height	2.26m	2.26m
Internal width	1.67m	1.79m
Internal length	3.16m	3.52m
Stall width	0.83m	0.89m
Stall length min/max	1.48/1.86m	1.67/2.05m
Breast/breeching bar height	1.11/1.32m	1.11/1.32m

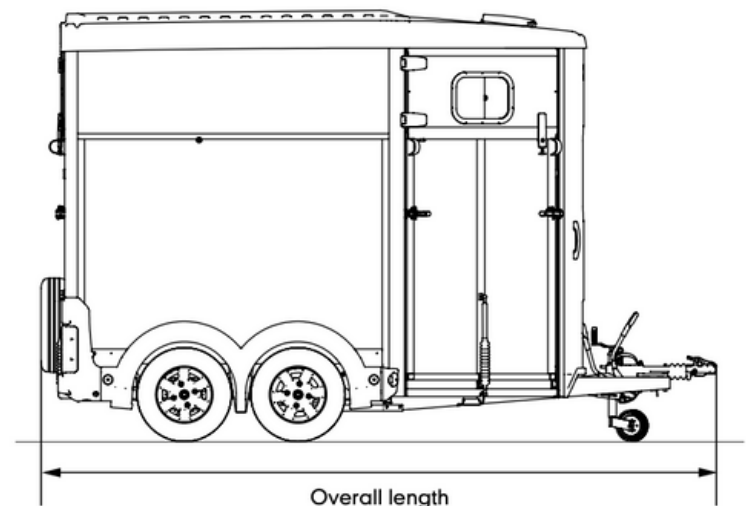
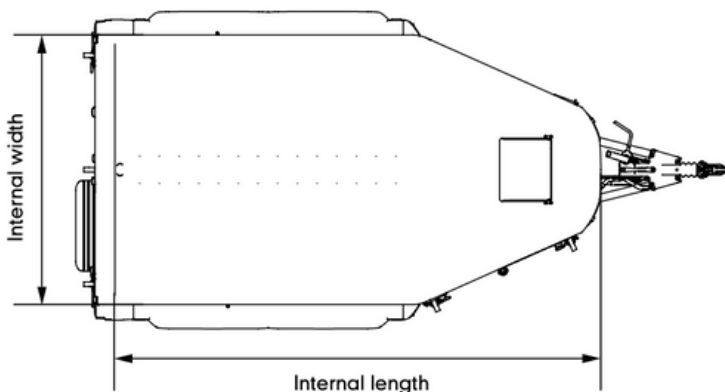

HOW WE ORDER YOUR BOX

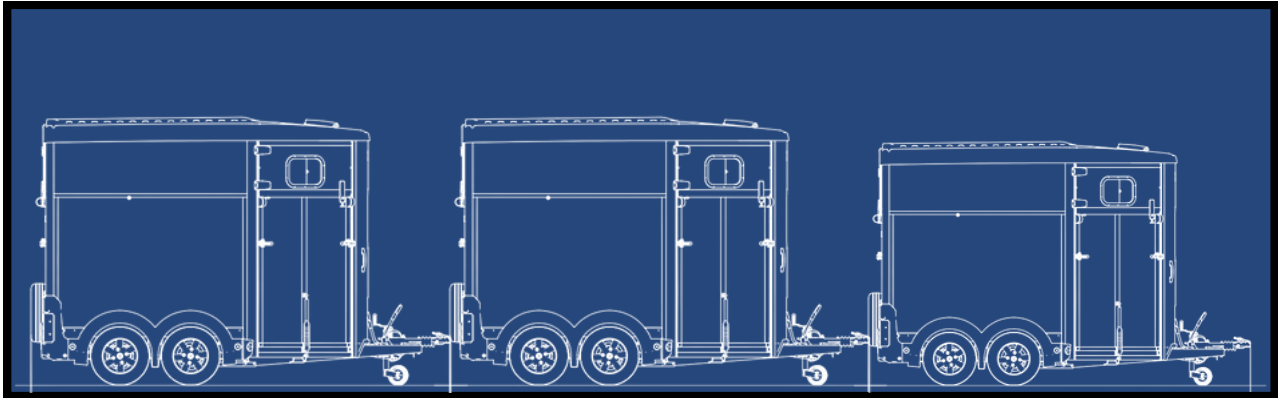

WHEN MAMPRO SA ORDER HORSE BOXES FROM IWT UK WE ORDER THEM IN CONTAINERS BY LOADS OF THREE. THIS LOAD WILL USUALLY CONTAIN 2X HB511/HBX511'S AND 1X HB506/HBX506

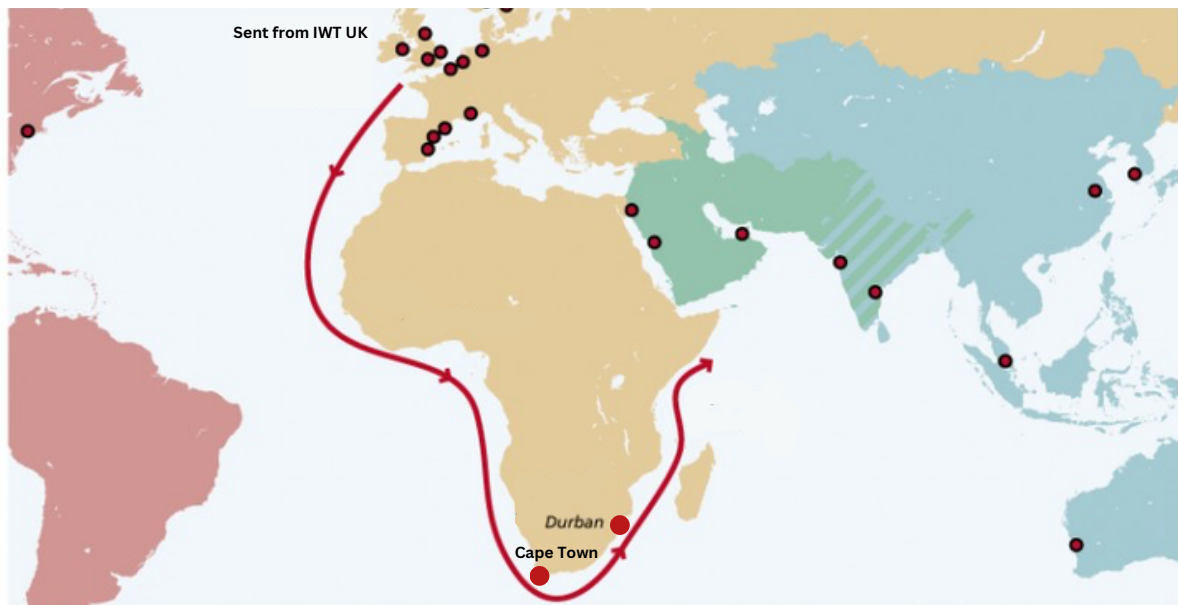

THE SHIPPING ROUTE OF AN ORDERED CONTAINER IS SHOWN IN THE IMAGE ABOVE. THE CONTAINER IS DISPATCHED FROM A UK DOCK AND SENT ON ITS WAY TO CAPE TOWN. A CONTAINER USUALLY TAKE 21 DAYS TO ARRIVE AT CAPE TOWN. AS MANY WILL KNOW THE CAPE TOWN DOCK IS INCREDIBLY UNRELIABLE, MAKING OUR TIMINGS FOR LOADS VERY UNPREDICTABLE. LOADS OFTEN BYPASS CAPE TOWN AND HEAD STRAIGHT TO DURBAN WHERE IT MAY SIT FOR UP TO TWO WEEKS BEFORE IT TAKES ANOTHER 3 DAY JOURNEY TO REACH CAPE TOWN. ONCE THE CONTAINER IS DISPATCHED FROM CAPE TOWN HARBOUR IT ARRIVES WITH MAMPRO SA IN DARLING, WESTERN CAPE. WE MAKE SURE THAT YOUR BOX IS 100% READY FOR DELIVERY. THIS CAN TAKE 2-3 DAYS BEFORE WE ARE READY TO DELIVER YOUR DREAM BOX RIGHT TO YOUR DOOR. THEREFORE, WE OFTEN GIVE TIME ESTIMATIONS AND WE WILL BE IN CONSTANT COMMUNICATION AS AND WHEN WE GET UPDATES!

We encourage potential clients to place advanced orders and pay deposits, so we can keep orders arriving and get your horse box to you as quickly as possible! Due to demand we rarely have stock on the ground.



MAMPRO SA

(PTY) LTD

26 CALEDON STREET
DARLING, WESTERN CAPE,
7345
0828900723 | 0826035516
INFO@MAMPROSA.CO.ZA
VAT REG: 4140271489

Product design, descriptions, colours, specifications etc. correct at time of going to press. Ifor Williams constantly strive to improve their products, and from time to time this may result in changes to the range or to individual models. Please check that design, description, colours, specifications described in this brochure are still valid at the time of placing an order.

Please be aware that prices change due to exchange rates from the SA rand to GB pound